

# DNG R1 jigging machine

Version 1.25

## Table of contents

Foreword .....	1
Overview.....	2
Features of the R1 jigging machine .....	2
Manual.....	2
Connection Diagram .....	3
Installation .....	4
Securing the machine .....	4
Electricity .....	4
Switching the power on .....	4
High and low voltage.....	4
Line and sinker .....	5
How to put the line on the drum:.....	5
The main parts of the reel.....	6
Control panel.....	7
Display .....	9
Pages, icons, and parameters .....	10
Page 1.....	10
Basic settings .....	10
Squid settings.....	12
Mackerel settings .....	14
Page 2 – Fishing settings .....	15
Page 3 – Various settings .....	18
Page 4 – Jig settings .....	20
Page 5 – Fishing systems .....	22
Page 6 – Infrequently used settings .....	26
Communication overview .....	29
Communication settings .....	29
WiFi settings .....	31
Keyboard.....	32
Additional properties.....	33
Set zero (zero depth) .....	33
Fast hauling .....	33

Slow hauling .....	33
Troubleshooting .....	34
The reel hauls the line without any fish .....	34
The reel won't move the drum and the voltage reads as 54V .....	34
The reel detects the bottom before hitting the seafloor .....	34
The reels pays out the line too slowly.....	34
The reel seems to have difficulty detecting the bottom and sometimes tangles the line .....	35
The reel always finds fish when it detects the bottom.....	35
The reel does not haul when it detects fish on the line .....	35

# Foreword

Dear customer,

We are thrilled to welcome you to the community of sailors who have chosen to incorporate the R1 jigging reel onto their boats. We want to provide you with some helpful tips and information to ensure you have the best experience possible.

This manual covers everything you need to know about setting up your jigging machine, connecting it to your boat's electric system, and configuring and using it. We highly recommend taking the time to read through the manual thoroughly. Previous users who have done so have encountered fewer problems and have been able to customise the machine to their specific needs. Even if you do not use all the features initially, having knowledge of them will make it easier for you to utilise them when you need to in the future.

The R1 jigging machine has undergone rigorous quality control tests, including waterproofing and pressure testing. We are confident the machine will provide you with many years of reliable use.

Lastly, we at DNG want to congratulate you on purchasing the R1 jigging machine. We believe it will deliver many successful catches for you in the years to come.

Sincerely,

DNG ehf.

Naustatangi 2, 600 Akureyri, Iceland

Phone: (+354) 460 2900

Email: [dng@dng.is](mailto:dng@dng.is)

# Overview

## Features of the R1 jigging machine

The R1 jigging machine is a very sophisticated device. Its primary function can be split into three parts. First, pay out the line with a weight at the leader and detect when it reaches the bottom. Second, jig to attract fish and detect when they bite. Third, haul the fish up to the surface.

Its main features include:

- High performance with low current consumption.
- Works on both 12V and 24V systems.
- Completely waterproof.
- Communication with other R1 machines.
- Built-in and customisable fishing systems.
- Fish searching system.
- Configurable to practically every situation.
- Special settings for mackerel and squid fishing.

## Manual

This manual intends to help you set up and use the R1 jigging machine, whether you are a new or an experienced user.

# Connection Diagram

Tengimynd  
Connection diagram

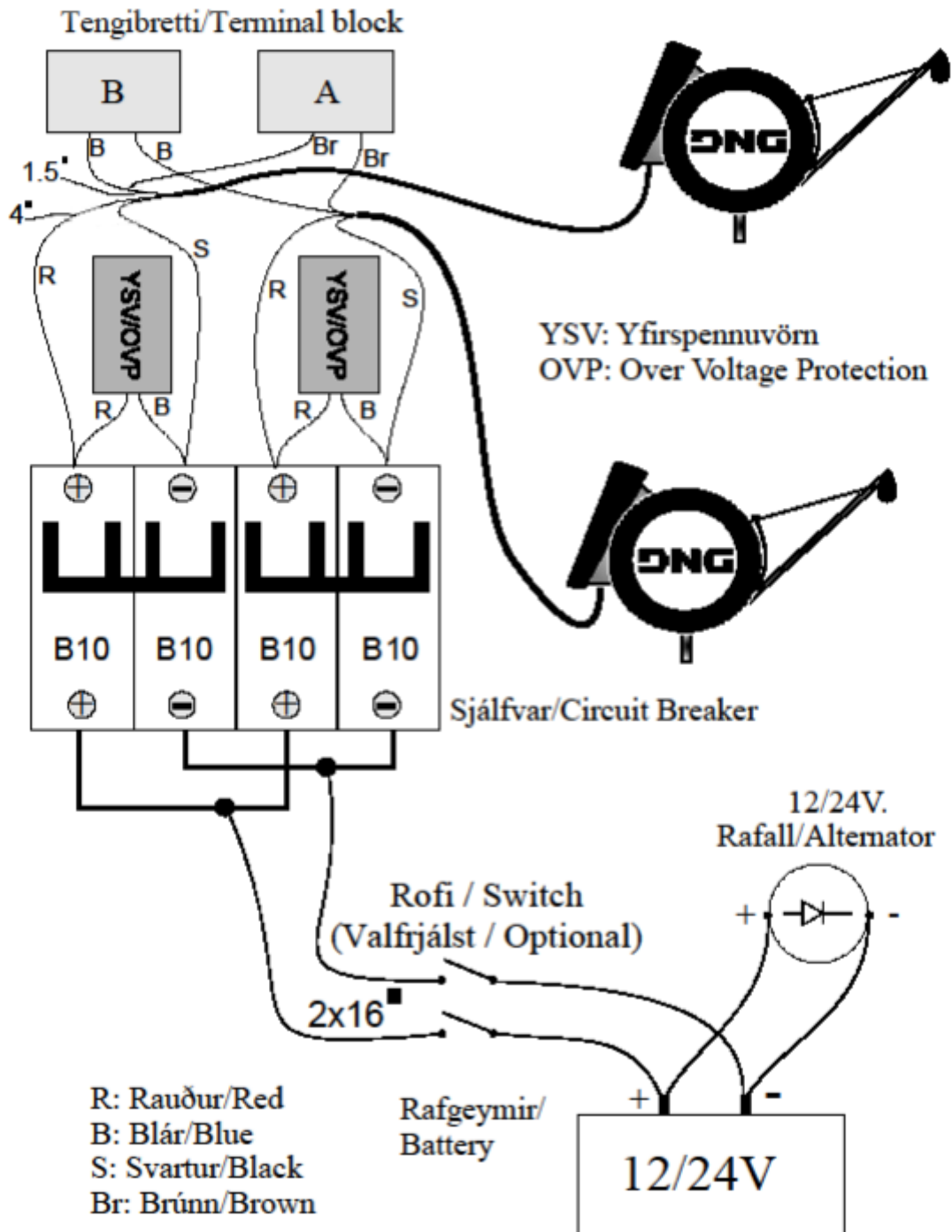

# Installation

## Securing the machine

The “foot” of the machine will fit into a one-inch pipe. It’s best to have a stainless-steel pipe securely fastened down (bolted down).

## Electricity

The electrical cable should not be too long or short. The cable has four wires: two 4 mm<sup>2</sup> power wires and two 1.5 mm<sup>2</sup> communication wires. The power wires are red (positive) and black (negative). The machine should be connected to a connection box from DNG or distributors. The connection box should include a two-pole circuit breaker for each machine and an overvoltage protection unit. The circuit breaker preferred is type B10.

The two communication wires are brown and blue. They should connect to a terminal block, as shown on the connection diagram.

Note: A polarity reversal will not harm the reel in any way, but it will result in an operational failure of the machine while incorrectly connected. If nothing happens on the screen when power is applied, check the polarity of the connection.

## Switching the power on

When the machine has been mounted and connected to the electric system, the power can be applied by the switch on the circuit breaker (or an optional switch). The machine may take a few seconds to perform a self-test and then displays the program version and serial number for 5 seconds. Then, the main screen will appear on the display. It is necessary to turn the drum as much as one turn to initialise. Then, the machine enters a Stop state, and the drum can no longer be rotated freely.

Note: Each time power is applied, the reel won’t work if not initialised by turning the drum. This will, however, happen automatically when the sinker is thrown overboard.

## High and low voltage

Suppose the voltage of the electrical system rises above approximately 32V. In that case, the overload voltage protection unit in the connection box will short-circuit the output of the circuit breaker, which then disconnects the reel from the electrical system. If, on the other hand, the voltage is too low (below 10V on a 12V system and below 20V on a 24V system), the machine will flash the value of the voltage measurement on the display and emit a sound as a warning. If the voltage continues to drop, it will finally result in an operational failure of the reel. This will, however, not harm the machine in any way, but it can damage the batteries of the electrical system.



# Line and sinker

When the reel has been mounted and power applied, the line is fitted on the drum. The figure above shows a typical configuration when fitting the line on the drum.

## How to put the line on the drum:

1. Remove the cap on the drum and fasten the line via the small hole near the drum's centre.
2. Press the MAIN button twice to start hauling the line.
3. Hold the line so that it is threaded tightly around the drum. Take care not to get your hand stuck in the wheel. Wear protective gloves.
4. If you are comfortable with more speed, you can press the UP button.
5. When the entire line has been fitted onto the drum, press the MAIN pad again to stop the reel.

Using a stop ring is unnecessary, but the "[Stop at zero](#)" setting must be enabled if you don't.

Note: The reel will not work correctly if the line does not go through the slack sensor arm

A sinker is used at the end of the leader. The reel is factory-tested with a sinker weighing 2 kg.



# The main parts of the reel

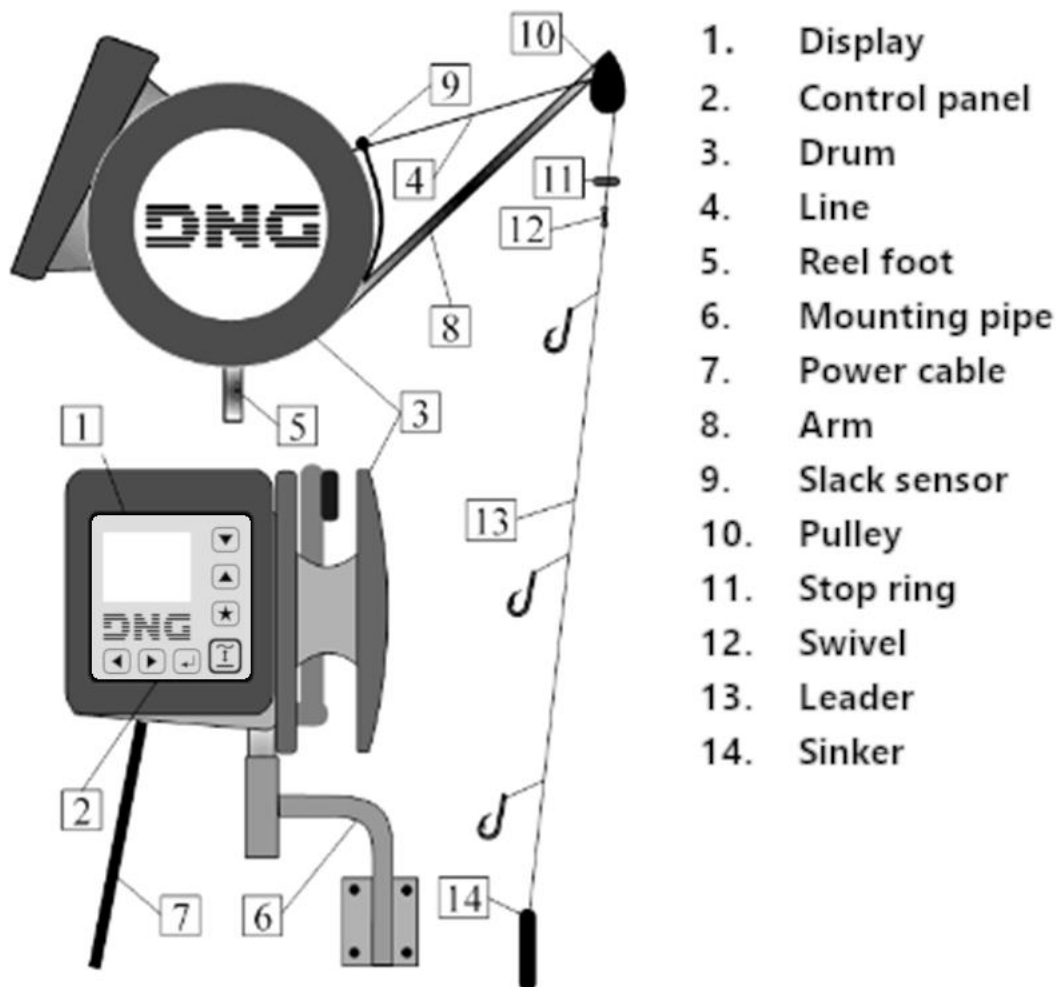

# Control panel

The parameters that control the reel are shown as icons on the display. The values of the parameters are shown below the icons.

Only a part of all the parameters and other information can be shown on the display at any time. The parameters are grouped into six categories on seven pages, and only one page is shown on the display simultaneously. Each page is labelled from 1 to 6. Page 5 is split into 5-1 and 5-2.

These pages also show other information like the speed of the drum, the battery voltage, etc.

The user can adjust the reel parameters by moving between these pages and changing their values. The reel is mainly operated from page 1.

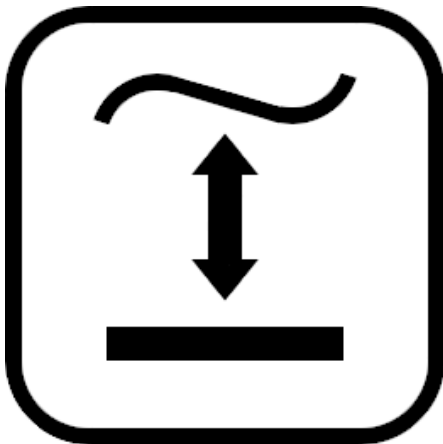

The MAIN button has two functions. Each time it is pressed, it switches the reel between three states, i.e., hauling, stop and pay-out. If the button is held for more than 5 seconds, the reel will enter a neutral state and release control of the drum, which can then be turned freely.

Note: If the sinker is in the water when entering a neutral state, it will pull out the line until it hits the seafloor, or the MAIN button is pressed again.



The STAR button's main function is to selecting icons on the current page.

When pressed once, an icon on the page will start blinking. That icon is the currently selected icon. If pressed again, the icon will stop blinking.

On a keyboard page, the STAR button is used to change pages.

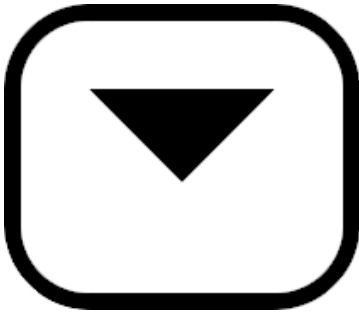

The DOWN button has three different functions. Navigating the page, decreasing a value, disabling parameters.

Its primary function is navigating the current page, i.e., when an icon is blinking, the button can be pressed to select the icon below.

It's also used to decrease a parameter's value when a parameter has been selected.

If pressed on page 1 while paying out the line, the false bottom will be disabled if it has been set. If the drum is stopped, it will zero out the current depth status.

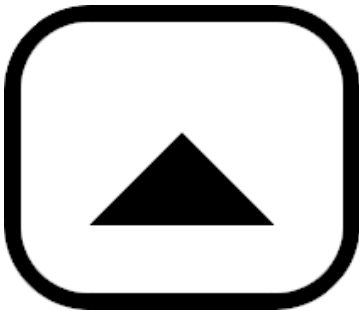

The UP button has three different functions. Navigating the page, increasing a value, and enabling a parameter.

Its primary function is navigating the current page, i.e., when an icon is blinking, the button can be pressed to select the icon above.

It's also used to increase a parameter's value when a parameter has been selected.

If pressed on page 1 while paying out the line, it will enable the false bottom at the current depth.

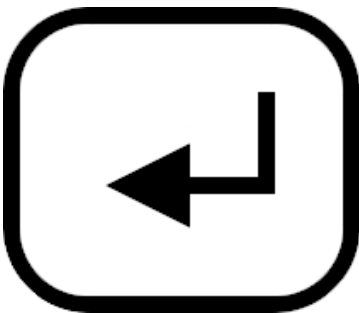

The ENTER button is used to select a blinking icon for changing. If a popup is open, the button is used to confirm the change. If no icon is blinking, the button will bring you back to page 1.

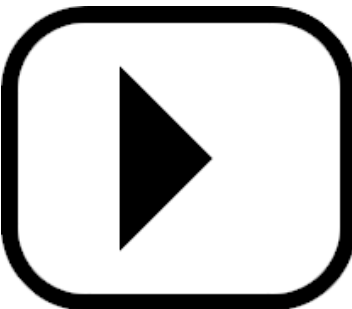
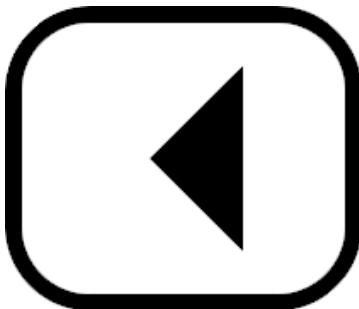

The LEFT and RIGHT arrow buttons are used to navigate the current page or, if no icon is blinking, to change the current page.

# Display

The top part of the screen is mainly used to display information such as depth, currently selected icon, current page number, current status of the reel, etc. Below are the icons for different statuses of the reel.

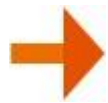

Jigging



Hauling



Custom  
jigging  
(1-4)



Stop



Paying out



Paying out  
slowly



If the reel detects fish on the hooks, a fish will appear on page 1, which shows the depth where the fish was detected. The icon will be removed if the fish escapes or when it reaches the surface. It will not appear if the user is altering parameters on one of the pages.

# Pages, icons, and parameters

## Page 1

### Basic settings



#### Fish sensitivity

The fish sensitivity is used to select how much weight must be added to the line (the weight of fish on the hooks) for the reel to haul it in automatically. The higher the fish sensitivity, the more weight must be added to the line before the reel hauls it in.

The reel detects (in each jigging action) how much power is required to haul in the line, and it compares this power to a calculated value based on the value of the fish sensitivity. If the power consumption exceeds this value, the line is hauled. If the fish sensitivity is set too low (compared to the weight of the sinker), the reel will bring up small fish or even haul when there are no fish.

This parameter has a range of 0 – 16. The factory default is 8.

Note: The fishing systems were made with a sinker weighing 2 kg, and the fish sensitivity is set accordingly. If a lighter sinker is used, a corresponding adjustment must be made to fish sensitivity, i.e., you decrease it. On the other hand, it must be increased if a heavier sinker is used.



#### Hauling power

This parameter controls the hauling speed and the line pull. The reel tries to maintain constant power. This means that if little weight is on the line, the speed is high. On the other hand, if there is much weight on the line, the speed will be low.

This behaviour is particularly important when fishing in rough seas because it minimises the risk of losing fish off the hooks when the boat is rocking in the waves. This is because even though the boat is rocking, the fish is pulled at almost constant speed up to the surface.

A higher number indicates more hauling speed and harder pull. The reel slows down for the last few meters before it stops when all the line has been hauled.



## Jigging power

The jigging action is performed at constant power. This means it is impossible to maintain the same jigging speed since the speed will depend on how much weight is on the line (how much fish is on the hooks). The more weight, the less speed. The higher the parameter value, the more power will be used when jigging upwards.

The value can be varied between 0 and 99, but the default value is 12.

Note: If, for a given value of jigging power, the weight on the line is enough to prevent the reel from turning the drum, then it will always interpret it as fish, no matter how high the value of the fish sensitivity.



## Jigging length

Jigging length is the span of each jigging action. Each step of the jigging length parameter equals 0.1 unit of the currently selected [unit system](#) (metres, feet, fathoms). Because the diameter of the line on the drum depends on the bulk of the line, the above figures are not entirely accurate.

If you have a very long line on the drum and are jigging at a small depth, the diameter of the line on the drum is big; hence, each step of the parameter is slightly more than 0.1 unit. On the other hand, if you are jigging at great depth and there is almost no line left on the drum, the diameter of the line is small; hence, each step of the parameter is less than 0.1 unit.



## Bottom margin

The bottom margin constitutes the minimum distance of the sinker from the seafloor during the jigging operation. Each time the sinker hits the seafloor, the reel will haul this length of line to maintain the distance from the seafloor according to the value of this parameter.

## Squid settings



On page 5 – 1 is an icon to select the [squid system](#). When active, pages 1 and 2 will change to show the special parameters used for squid fishing.

Note: When the squid system is active, the reel will ignore the slack sensor, so threading the line through is unnecessary.



### Decrease depth

Each time the line is paid out, the depth at which the reel starts to haul is decreased by this value. This is useful when light is used to attract the squid up to the surface. The squid is then constantly moving upwards, and the depth that the reel must start hauling must be decreased each time the line is paid out.



### Pulling time

When the line is hauled in, the power is periodically changed. This parameter controls the duration of the period when the power is increased, i.e., the line is pulled.



### Relax time

This parameter denotes the duration of the period where the hauling power is decreased, i.e., the line is not pulled.



### Release waiting time

When the reel has hauled the line in altogether, it stops for a period before it pays out the line again. Each step equals 1 second, and the default value is 2.

This can be useful to ensure that the squid on the last hook has released the hooks before the line is released into the water again.



### Haul waiting time

The duration of a complete stop when the line has been paid out to the depth of the false bottom before the reel starts hauling the line. The default value is 0.



### Maximum hauling speed

The maximum speed when hauling in the line, i.e., the reel will never exceed this speed when hauling the line, no matter the value of the [hauling power](#).

This parameter is necessary when fishing with many hooks and/or strippers, e.g., when fishing for mackerel. In that case, the power must be sufficient to haul the line when there is fish on every hook and to tear the fish off the hooks by pulling them through the stripper. But when there isn't fish on every hook, the reel would haul it very fast, making the "tear off" process hard to control.

The default value is 250, but the value can be varied from 0 to 500. Each step equals 10 RPM. This default value should be suitable in most cases, but if fish tends to be thrown into the sea during the "tear-off" process, decrease this value.



## Mackerel settings



On page 5 – 1 is an icon to select the [mackerel system](#). When active, pages 1 and 2 will change to show the special parameters used for mackerel fishing.

The jigging reel can be used without accessories for mackerel fishing, just like when fishing for cod, pollock, etc. But since the fish must then be stripped off the hooks by hand and the leader must also be hauled in by hand (it cannot be wound onto the drum), this is a very tedious job. It's much more efficient to use a stripper and pulleys. The high pulling force capability of the reel makes it possible to have up to 70 hooks on the leader.

When fishing for mackerel with the R1 and a stripper, the mackerel program is selected. The leader usually has 30 - 70 hooks approximately 30 – 40 cm from each other. The length of the leader (and consequently the number of hooks) depends on how long a line the pulleys can accommodate. The same thing applies as for squid fishing, i.e., the hooks can never be reeled onto the drum.

The hooks used for mackerel fishing are different from those used for conventional jigging. They are smaller, and usually, only red-coloured artificial bait (rubber) is used.

When the mackerel has been spotted underneath the boat, the line is paid out until it reaches the same depth as the mackerel. Then, a false bottom is set at that depth. The reel will start hauling the line until it reaches zero depth. Then, it stops for a while before it pays out the line again. When it reaches the depth of the false bottom, it will start hauling the line, and everything starts over again.





## Step number

Sets the number of steps used in "step jigging". The default setting is 5.



## Mud bottom

If fishing is carried out on a very soft seafloor (mud or sand), the sinker may get buried, and the reel thus wants to interpret the resistance as fish if this parameter is not used. If enabled, the reel does not try to detect fish in the first few rounds of the drum, and hence, there is no chance that the reel will mistake the mud for fish.

By default, this parameter is disabled.



## Bottom sensing time

This parameter controls the bottom sensing time. The higher the number, the longer the slack duration must be before the reel interprets it as having hit the seafloor. The default is 1.3 seconds.

The line goes through the loop on the slack sensor arm, and when the line is taut, it pulls the arm down. On the other hand, when there is slack on the line, a spring will pull the slack sensor arm back up, and the reel will know there is slack on the line. Therefore, it is essential that the slack sensor arm can move freely.

If the value is too low, the reel will quickly interpret any slack as the bottom. This can, however, be useful if the bottom is rocky to prevent the sinker from getting stuck between rocks.

On the other hand, it can be inconvenient when the sea is choppy. When the boat is rocking in the waves, there will, occasionally, be a slack on the line even though the sinker has not reached the seafloor. In this case, it is necessary to increase the value of this parameter.

When a small fish bites the hooks (not big enough for the [fish sensitivity](#) to trigger), and the reel keeps on jigging, it will not be able to jig as fast downwards since the fish resists the downward pull of the sinker. In this situation, the reel sometimes erroneously concludes that it has hit the seafloor. Due to this, the reel jigs a shorter distance downwards than it jigs upwards

and hence is slowly moving away from the seafloor. A solution to this problem is to increase the value of this parameter. This has the drawback of delaying the bottom sensing when the sinker hits the seafloor. This delay can lead to loss of the sinker when fishing on a rocky seafloor, e.g., a volcanic rock field.



## Drift

This parameter is used when fishing in heavy drift conditions. If not in zero position, the reel will haul the line in altogether and then pay it out again automatically. This ensures the line does not stray from the boat while the fish is underneath.

This setting is off by default but can be set to Time, Distance, or Percent.



## Drift - Time

The frequency at which the line is hauled in a drift system. Each step corresponds to 1 minute.



## Drift - Distance and Drift - Percent

These settings do not work in version 1.25.



## Brake

If this parameter is above 0, the motor will not pay out the line; instead, the sinker will pull the line. The higher the value, the more resistance of the motor. This also disables the slack sensor, so the reel will detect the bottom when the drum stops spinning.

## Page 3 – Various settings



### Slack sensor up and down

These are the values of the slack sensor in its up and down position. The “up” value is the value of the slack sensor when there is no strain on the line, while the “down” value is the value when completely down. If set correctly, there should be a decent gap between the numbers.

Note: The most common cause for errors is these values being set incorrectly. If you encounter odd jiggling behaviour, try resetting these values.



### Bottom sensing slack

There will be slack on the line when the sinker hits the bottom. If the signal drops below this value for a certain amount of time (see [Bottom sensing time](#)), the reel will interpret it as the bottom. This value, below which the slack sensor signal must drop, is determined by this parameter. The default value is 14, but it can be varied between 1 and 48.

In some cases, when there is not much line left on the drum, it might be necessary to decrease the value of this parameter. This could happen when fishing at much depth or when there is not enough line on the drum.

In these cases, the slack sensor arm is not pulled down far enough when the line is taut, and the slack sensor signal will be close to 14 or even below. If the slack sensor signal drops below 20, the pay out speed will drop considerably, and the risk of detecting the bottom falsely due to the rocking of the boat will increase a lot.



### Maximum pay out speed

This parameter controls the maximum speed when paying out. Each step equals 10 RPM, and the default value is 380 RPM. The value can be varied between 0 and 600.

The best value of this parameter depends on circumstances and the type of line on the reel. If the sea is choppy, it may be necessary to decrease this parameter. However, if the sea is calm, it may be possible to increase the value of this parameter and hence gain more speed and efficiency.



### Maximum hauling speed

The maximum speed when hauling in the line, i.e., the reel, will never exceed this speed when hauling the line, no matter the value of the hauling power. If too much weight is on the line, the reel might not reach the maximum speed unless the [hauling power](#) is increased.



### Stop at zero

If enabled, this parameter tells the reel to stop once the depth counter reaches zero when hauling in the line. If disabled, the reel hauls the line until the stop ring reaches the pulley.



### Factory reset

If you are in trouble and have lost your way in all the parameters, you can reset the reel by activating this function.

## Page 4 – Jig settings

On this page, you can change the jigging settings and even record your own jigging type. i.e., you can turn the drum, and the reel will record your movements so you can use them later.



### DNG jig

The standard jigging action, going up and down, sensing fish when moving up.



### Speed controlled downward jig

If disabled, the reel will pay out the line as fast as "[maximum pay out speed](#)" when jigging downwards. If enabled, the reel will control the speed of the downward jig and try to maintain the speed set by the "[jigging down speed](#)".



### Jigging down speed

This parameter controls the speed of the downwards jig if the "[speed controlled downward jig](#)" is activated. This value is also used when paying out slowly. The default value is 80 RPM.



### Jigging power to hauling power

When the reel detects fish on the line, it changes states from jigging to hauling. Since fish is detected when jigging upwards, the only change is the power, i.e., from [jigging](#) to [hauling power](#). To avoid losing the fish off the hooks, the reel increases the power ten times slower than normally when hauling. This is done the first few meters. The number of meters that the reel behaves this way is controlled by this parameter. Each step equals 0.1m. The default value is 5m. The parameter can be varied between 0 and 20m.



## Tangle detection

This parameter, if set to a value above zero, activates the tangling detection, i.e., the machine will detect if the line is tangled with the line/leader from the next jigging machine.

If the reel cannot start a single downward jig (due to slack on the line) many times in a row, it is a sign that the depth is decreasing rapidly or, more likely, two reels on the same boat have their leaders tangled.

As an example of how it works, let's say that the value is set to 2 (the default value). Now, the reel can detect the bottom two times in a row without being able to start a single downward jig (due to slack on the line). If it happens three times in a row, the reel interprets it as "a tangle" and starts hauling.

If the parameter is set to 0, this feature will be inactive.



## Custom jig

You can record your own jig and store the recording in memories labelled 1 to 4.

This is done as follows:

First, while the reel is in the stop state, select the desired number to configure and press the ENTER button. When ready, press the DOWN button and start the jigging movement you wish to record. The reel can record up to 80 seconds of jigging, but you don't have to use the entire 80 seconds.

When you've finished the jigging movement, press the DOWN button again. The jig is now saved and can be selected with the ENTER button.

Note: The reel starts recording the moment you press the DOWN button, so if any time passes between pressing the button and moving the wheel, that time will also be recorded.



## Page 5 – Fishing systems

Fishing systems hold stored values for all parameters on page 1. They also include information on what type of jig should be used, and they always set the number of steps for "[step jiggling](#)" to a value of five.

The fishing systems also store information about the downward jig, i.e., the factory-made systems always disable [speed controlled downward jig](#), unless it's a custom fishing system.

Selecting a fishing system with the ENTER button activates that fishing system. When a system has been activated, the corresponding icon will be displayed on page 1. Search systems differ from the other systems since they do not hold values for any parameters or jiggling type.

If a search system is activated, the reel will use the active fishing system to search the sea for fish, i.e., it will jig a defined number of times (default: 10) at one depth, then haul one [jig length](#) and start jiggling again, then haul one jig length etc. When it reaches the top of the search span, it will check for the bottom and start again. The icons show the defined search span. If the reel finds fish, it sets a false bottom at that depth, deactivates the search system and hauls the fish. Next time the user makes the reel pay out, it will stop at the depth where the fish was caught and start jiggling.



### DNG

This system holds the factory default settings. This is the active system when the reel is connected to a power source for the first time.

If you have trouble and have lost your way in all the parameters, you can set the basic parameters to the factory setting by activating this fishing system.



### Fishing with bait

This system is used when bait is used on the hooks instead of rubber. When fishing with bait, the reel waits shortly at the bottom and top of the jiggling motion and jigs in short and slow movements. Fish sensitivity is low.



## Pollock fishing

Pollock fishing uses rapid jigging and high fish sensitivity. Since it is not likely that the fish will get off the hook, a powerful hauling force is used for increased efficiency.



## Step jigging

This system is similar to fishing with bait, but instead of going up and down, the reel jigs upwards a defined number of times (see [step number](#)), waiting slightly between each jig upwards. When completed, it will go down to the depth where the first jig was made and start again.



## Squid fishing

This system is very much different from the other systems. This is because the method used for squid fishing differs from the conventional jigging method.



## Mackerel fishing

This system is similar to the squid fishing system but uses a stripper to fish for mackerel. For a more detailed explanation, see [Mackerel settings](#).



### Norwegian system

A system used for deep water, using long jigs.



### Faroese System

A system that stops for 10 seconds at the surface.



### Brake system

This system is unique because it does not use the slack sensor. The motor will not pay out the line; instead, the sinker will pull the line. The higher the value of the "[brake](#)" parameter, the more the motor will resist the pull. The reel will detect the bottom when the drum stops spinning.



### Winching

A system for winching. There's no jigging; the reel will just switch between hauling and stopping when the MAIN button is pressed.



### Scottish mackerel

A special mackerel system used in Scotland.



## Mackerel belt system

A mackerel system used with the DNG-FS1 mackerel fishing equipment.



## Total search

In this search system, the search span is from the bottom to the surface. If a false bottom is set at some depth, it will search from that depth up to the surface.



## Bottom search

The search span is from the bottom and halfway to the surface. A false bottom can be set to change the bottom of the search span.



## Surface search

This system is just like the total search system with a false bottom at a depth of 8 times the jigging length. It automatically sets the false bottom at this depth and then searches from there to the surface. If the depth at the bottom is less than eight times the jigging length, the false bottom will be set at that depth, and each time the sinker hits the bottom, the false bottom will be set accordingly.



## Custom fishing system

Due to a programming error, saving a custom fishing system in version 1.25 is impossible.

## Page 6 – Infrequently used settings



### Language

This switches the display language between Icelandic and English.



### Brightness

Sets the brightness of the display. By default, the brightness is set to 10, but it can be lowered, e.g., when fishing in dark conditions.



### Buzzer

If active, the reel will buzz when it detects fish and when the line is hauled to the surface. This setting does not affect button press noises.



### Whistle when up

This parameter controls when (at what depth) the reel will whistle when it has hauled the catch up to the surface. This is disabled by default.

This feature can be essential, e.g., when fishing for cod, since the fish sometimes escapes if someone isn't ready to grab the leader and continue hauling it before the reel has come to a complete stop.



## Pay out automatically

If set above zero, the reel will wait for that number of seconds before automatically paying the line out again. If this is set to zero, the reel will not pay out the line until the MAIN button is pressed again.



## Power factor

This parameter controls the elasticity of the hauling action. The lower the value, the softer (gentler) the hauling action. The power factor can be adjusted from 0 to 10, but the default value (after reset) is 3.

As an example of how the power factor works, let's say that its value has been set at 3. Now, the reel will use 30% of the power, as set by the [hauling power](#) parameter when the speed is 0 RPM and 100% when the speed is 500 RPM. At any other speed, the power is linearly interpolated between these two values. In this case, the power used at 250 RPM would be 65%.

This has the effect that if the power factor is set at a low value, e.g., 0-5, then the reel will haul in slowly and elastically when there is some weight on the line but hauls in fast and powerfully if there is not. If the power factor is set at 10, the reel will use full power at all speeds.

If set to a low value, it can help counteract the movement of the boat on the waves so that the fish is hauled at a consistent speed.

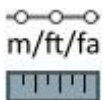

## Unit of measurement

This parameter changes the unit in which units are shown on the display. You can choose between meters, feet and fathoms. Below the icon, there is a label that indicates the current unit (m = meters, ft = feet, fa = fathoms)



## PIN lock

The reel can be locked with a 4-number PIN code. If active, you must enter the PIN code every time you turn on the reel. To set a PIN code, select this setting and enable it. Once it's enabled, you will be prompted to enter a code. Press ENTER and re-enter the code to confirm it. You can also disable the lock with this setting.

Note: You must remember the PIN code you selected. If the reel is locked with a forgotten PIN code, bypassing it is impossible. The reel must then be sent to DNG to reset it.

## Communication overview

If the reel is connected to other reels via WiFi or Serial V2 communications, their status can be seen on this page. The reel with the communication ID 1 can also control the other reels by selecting them and using the MAIN button to send them commands.

## Communication settings

On this page, you can change the communication method the reel uses.



### Communication method

This parameter changes the communication method used by the reel. The available methods are Wi-Fi, Serial V1, and Serial V2. Change the method with the UP and DOWN buttons.

## COM ID

### Communication ID

This is the reel's ID for communications. If set to 0, the reel will not communicate with other reels. If set to 1, this reel is the controller and can send commands to other reels from the communication overview page. Otherwise, the ID can be set to 2 – 5.

Note: Multiple reels cannot use the same ID. If more than one reel shares an ID, it will cause communication errors.



### Whistle when up

See [Whistle when up](#)





## External buzzer

If this reel is connected to an external buzzer and uses the Serial V1 communication method, this parameter changes the buzzer sound. This does not affect the internal buzzer (see [Buzzer](#)). If set to 0, this reel will not use the external buzzer.



## Always at least one jigging

Due to a programming error, this setting does not work in version 1.25.

## WiFi settings

This page handles the WiFi communications.



### WiFi

If this icon is visible, the reel is configured to connect to a WiFi network. If you select this icon and press the UP button, this icon will change to the WiFi AP icon.

If the reel is connected to a WiFi network, the display will show "Connected to WIFI" along with the name of the network and this reel's IP.



### WiFi AP

If this icon is visible, the reel is configured to create its own WiFi access point. The reel can do this without input from the user. If you select this icon and press the DOWN button, it will change to the WiFi icon and drop its access point.

When the reel has set up its own access point, the display will show "Created WifiAP" along with the access point name and IP. Other reels can now connect directly to this reel without using a router.

Note: this access point is open and does not have a password. When prompted for a password when connecting to it, leave the field blank.



### Scan for WiFi

Before the reel can connect to a network, it must scan for available networks. When selected with the ENTER button, the reel will start scanning for available networks.

When the scan is finished, a list of available networks will appear. You can navigate the list with the UP and DOWN buttons and select a network with the ENTER button.

## Keyboard

You will be prompted for the WiFi password when a network is selected. You can navigate the keyboard with the arrow buttons and select a letter with the ENTER button. You can select the "←" icon to erase a letter.

There are four different keyboard pages, which can be switched with the STAR button.

Keyboard page 1: Lowercase letters

Keyboard page 2: Uppercase letters

Keyboard page 3: Numbers and symbols

Keyboard page 4: Icelandic letters

When the password has been entered, save it using the "Save" icon.

Note: The "Save" and "Cancel" icons are not visible on keyboard page 3 due to space.

# Additional properties

While the buttons have their primary functions, they also have some special functions.

## Set zero (zero depth)

Pressing the DOWN button while no icon is blinking on page 1 and the reel is in the stop state will set the current point as the zero point.

This may be necessary when a new line is put on the drum or when the line breaks and is, therefore, shorter.

You may also just not want the reel to haul the line up.

## Fast hauling

The hauling speed can be temporarily increased without changing the value of the [power factor](#) or [hauling power](#) by pressing the UP button while the reel is hauling. If pressed once, the [power factor](#) is set to 100%. After that, the [hauling power](#) is increased by 10% each time it is pressed.

These values will automatically return to their previous values when the line has been hauled or when the DOWN button is pressed.

This can be useful if the boat needs to be moved quickly and the line needs to be hauled. Press the MAIN button to start hauling, then press the UP button a few times to reach the maximum hauling speed.

## Slow hauling

The hauling speed can be temporarily decreased similarly by pressing the DOWN button while hauling. If pressed once, the [power factor](#) is set to 0%. After that, the [hauling power](#) is decreased by 10% each time it is pressed.

These values will automatically return to their previous values when the line has been hauled or when the UP button is pressed.

This can be useful if the line gets tangled and needs to be carefully untangled.

# Troubleshooting

## The reel hauls the line without any fish

There are three likely culprits for this. The [fish sensitivity](#) value may be too low compared to the weight of the sinker used in the line. The [drift](#) system might be active, causing the reel to automatically haul the line periodically. If this only happens when the sinker hits the seafloor, the seafloor might likely be muddy or sandy, causing the sinker to sink into the soil. This can be fixed by enabling the [mud bottom](#) setting.

## The reel won't move the drum and the voltage reads as 54V

This used to happen in the older c6000i reels, but we have never observed it happening in the R1.

If this does happen to you, try disconnecting the reel from its power source for at least 10 seconds before reconnecting it.

If that does not solve the problem, contact your local DNG distributor.

## The reel detects the bottom before hitting the seafloor

The simplest cause for this problem is a false bottom is set. To disable the false bottom, press the down button while the reel is paying out the line.

If a false bottom is not set, check the [slack sensor up and down](#) values.

If those values are set correctly, and the problem persists, Try increasing the [bottom sensing time](#) value and/or decreasing the [bottom sensing slack](#) value.

## The reels pays out the line too slowly

The most likely reason for this is that the [slack sensor up and down](#) values are set incorrectly.

Make sure the motor is not in the "paying out slowly" state.

Check the value of [maximum pay out speed](#).

Check the value of [bottom sensing slack](#).

## The reel seems to have difficulty detecting the bottom and sometimes tangles the line

A correctly configured slack sensor is key when the reel pays out the line and detects the bottom. Check the [slack sensor up and down](#) values.

[Bottom sensing time](#) also plays an important role, but regardless of its value, the reel will always stop if the slack value reaches the “slack up” value.

## The reel always finds fish when it detects the bottom.

The seafloor might be muddy or sandy, causing the sinker to sink into the soil. This can be fixed by enabling the [mud bottom](#) setting.

## The reel does not haul when it detects fish on the line

This happens if the [communication method](#) is set to Serial V1 and [always at least one jigging](#) is enabled. This is a known problem that will be fixed in future versions.